

NEW

*IP68 marine-grade
option for wet and
salty environments*



H-Track

Electro-Hydraulic Linear Actuator

Featuring Power Density and Shock Load Resistance



H-Track – A Compact Hybrid of Superior Performance

H-Track electro-hydraulic actuators provide the high load performance of hydraulics without the expansive space requirements nor the prohibitive cost of full-sized, fluid-based systems.

More Power in Less Space

H-Track electro-hydraulic actuators feature the smallest mounting envelope in their class with a patented valve and reservoir design that provides significant space savings compared to competitive models. H-Track is a robust linear actuator providing force up to 4800 lbf (21350 N) and travel speeds near 4 in (100 mm) per second. With stroke lengths up to 12 in (300 mm), different piston end adapters and multiple configurations available, the H-Track offers a unique set of options for machine designers.

Made for Tough Conditions

H-Track actuators are weatherproof, dust tight, corrosion resistant, and tested for IP67 static (temporary submersion) and IP69K (high-pressure washdown). With the marine-grade motor option, it is also IP68 approved (tested for continuously submerged operation up to 2 m for 650 hours). The H-Track offers an optional operation temperature from as low as -40°F (-40°C) to as high as 180°F (82°C), making it an ideal option for applications in demanding conditions.



Completely Self-Contained

The motor, pump and valves are contained in one mini power pack mounted directly to the combined cylinder/fluid tank. This means that the inner workings are completely sealed from the outside, allowing this unique arrangement to minimize parts and improve performance. Unlike hydraulic cylinders, there is no need for external hoses, valves, reservoirs or hydraulic connectors that can break or leak. The operation is as simple as with a traditional electric actuator - just turn the supply voltage on to move and change polarity to reverse direction. If necessary, the actuator piston rod can be manually overridden, allowing the rod to float for operating in emergency situations.

THE BEST OF TWO WORLDS

ELECTRICALLY POWERED AND CONTROLLED

- SIMPLE TO CONTROL
- NO NEED FOR BULKY EXTERNAL HOSES, VALVES OR PUMPS
- MINIMAL RISK OF LEAKAGE
- MAINTENANCE FREE

HYDRAULIC MOTION

- HIGH POWER DENSITY
- HIGH SHOCK LOAD AND VIBRATION RESISTANCE
- SMOOTH MOTION
- QUIET OPERATION





Electro-Hydraulic Advantages

The best features from the electric and hydraulic actuator worlds have been chosen to power the H-Track linear actuator, giving it a unique set of capabilities that allow it to be used in applications that otherwise might be too difficult for other solutions to take on.

Compact Design

H-Track actuators have a mounting length that is shorter than any other electromechanical actuator on the market. It can fit into applications with a pin-to-pin length as small as 4.73 in (120 mm) plus its stroke, and still provide up to 3200 lbf (14234 N) of force.

Superb Load-Holding Power

H-Track actuators operate in both tension and compression and will hold a load stationary without power in either direction. Static load-holding capability will always exceed the dynamic load moving capability.

Vibration and Shock Load Resistant

H-Track actuators are immune to vibrational drifting, hydraulically self lock and safely absorb shocks.

Energy Efficient

Electric control provides clean, smooth linear motion without hydraulic plumbing or other expensive componentry. The H-Track's power demands are significantly less than those of a full hydraulic system as the actuators require power only when in motion.

Solid Piston

Since the piston is solid, it allows for increased resistance to buckling compared to a hollow piston rod of the same size.



Hydraulics Isolated from the Atmosphere

The fluid reservoir is vented and isolated from the atmosphere with a flexible lid, allowing actuator and pump operation in any orientation without entraining or cavitation.

Maintenance-Free

H-Track actuators require no lubrication, hydraulic fluid fillup, or any other type of maintenance or adjustments for their entire lifecycle.

Contamination-Free

The H-Track's pump is conditioned and flushed prior to vacuum-filling the completed actuator assembly with degassed hydraulic fluid. This ensures you enjoy contaminant-free performance for the life of the actuator.

Thoroughly Tested

Throughout their entire development process, H-Track actuators are rigorously tested to ensure they meet all relevant standards and performance specifications prior to leaving the factory. Please contact Thomson customer support to learn more about which standards H-Track meets and how our testing is carried out.

Customization

As with most Thomson products, H-Track actuators can be customized. Our engineers will work with you to determine the modifications needed – from a simple color change to a complete overhaul of the design. Thomson is a global leader in custom actuator production and takes pride in supplying the optimal solution to each customer.





Built to Perform

H-Track is built from the outside in to excel in situations where many other actuators are forced to bow out. The unique electro-hydraulic design combines the best features from two distinct systems and opens up new application possibilities for linear actuators.

MORE POWER IN LESS SPACE

H-Track is one of the strongest actuators for its size without compromising life expectancy or the ability to withstand the elements.

- 1 **Compact and strong power pack unit, containing pump, valves and motor**
- 2 **Fluid tank integrated into the cover tube**
- 3 **Solid small-diameter, buckling-resistant piston rod**

COMPLETELY SELF CONTAINED

Get the best from the electric and hydraulic worlds in one package. H-Track is powerful, tough, and vibration and shock load resistant. Yet it only needs a battery and a switch to run, requires no maintenance, and minimizes the risks and hazards associated with hydraulic fluid leaks.

- 4 **Power pack unit completely sealed from the outside**
- 5 **Two-wire operation**
- 6 **Large number of power pack and cylinder configurations allow for great design flexibility**

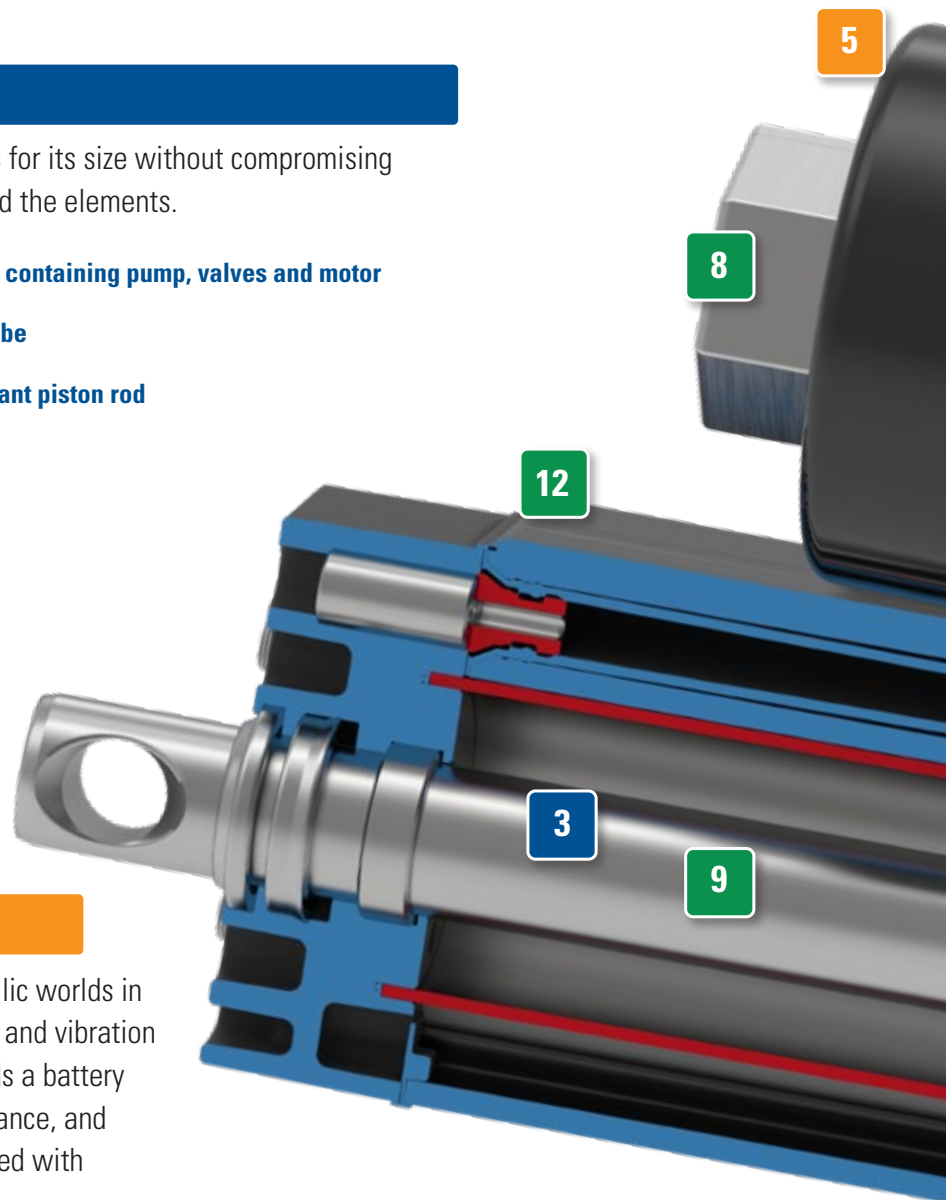

MADE FOR TOUGH CONDITIONS

H-Track is designed and tested to operate under the harshest conditions without failure or the need for maintenance.

- 7** Standard IP69K/IP67 protection class and tested for 2000 hours salt spray
- 8** IP68 and tested for 650 hours under water (marine-grade option)
- 9** Solid 316 stainless steel piston
- 10** Large operating temperature range
- 11** High shock load and vibration resistance
- 12** Anodized aluminum-alloy housing

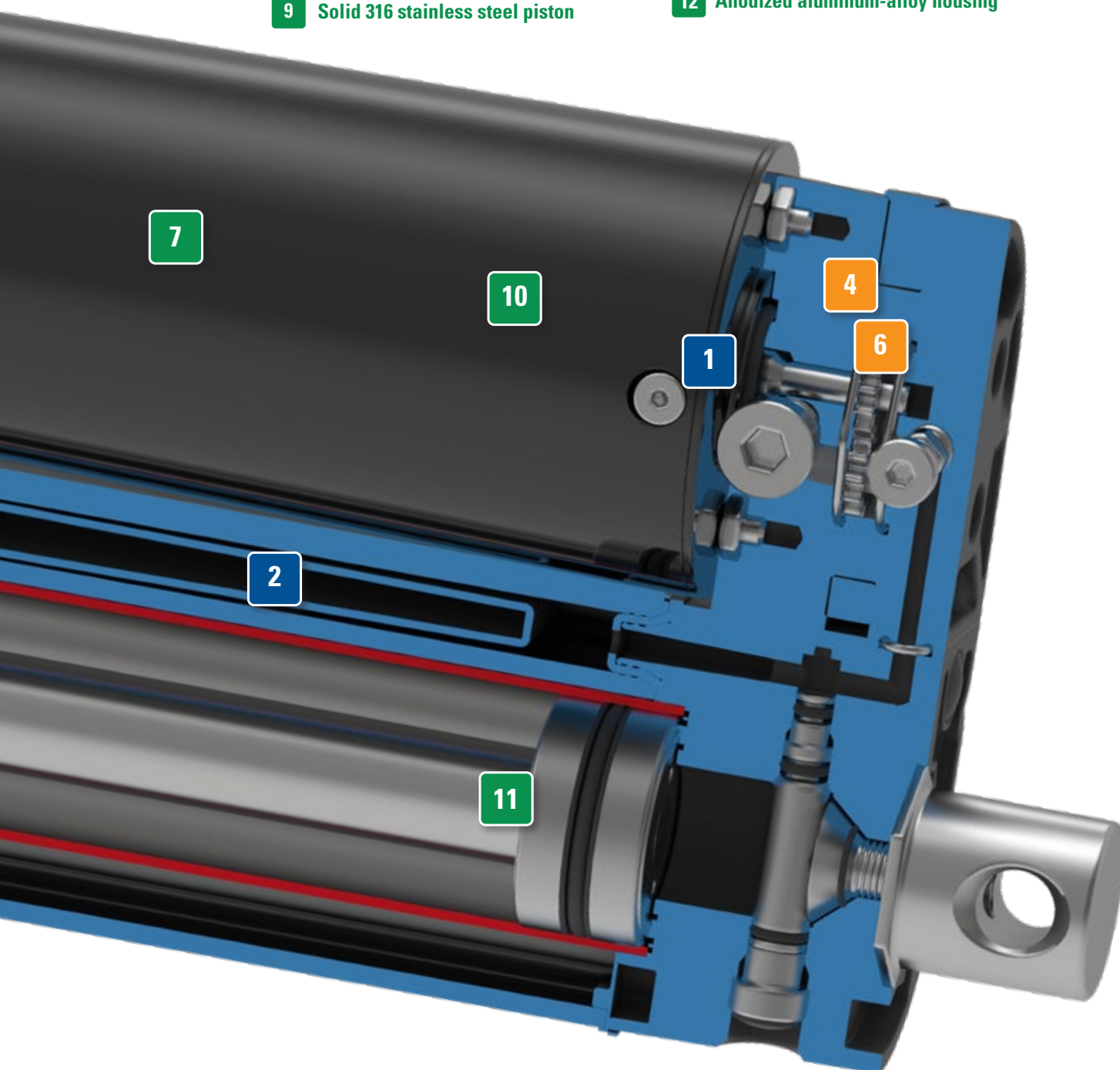



Built for the Toughest Applications

With a self-contained electro-hydraulic system, H-Track actuators meet the growing demand for power-dense performance used in a variety of industrial, agricultural and marine applications.

Designed to Withstand Life on the Fields

With agricultural sprayers becoming larger and boom lengths reaching up to 177 ft (54 m), strain on the actuators has increased exponentially. Actuators are used to fold the long sprayer booms from an extended position to a stowed position for transport. The folding and unfolding of these booms apply

very high loads on the actuators. The strain on the units is dramatically increased when the sprayer is in motion, and the bouncing of the booms causes even more extreme loads. These combined loads create tremendous impact force that can easily destroy most other electric actuators. The H-Track is designed to handle this type of loading with ease.

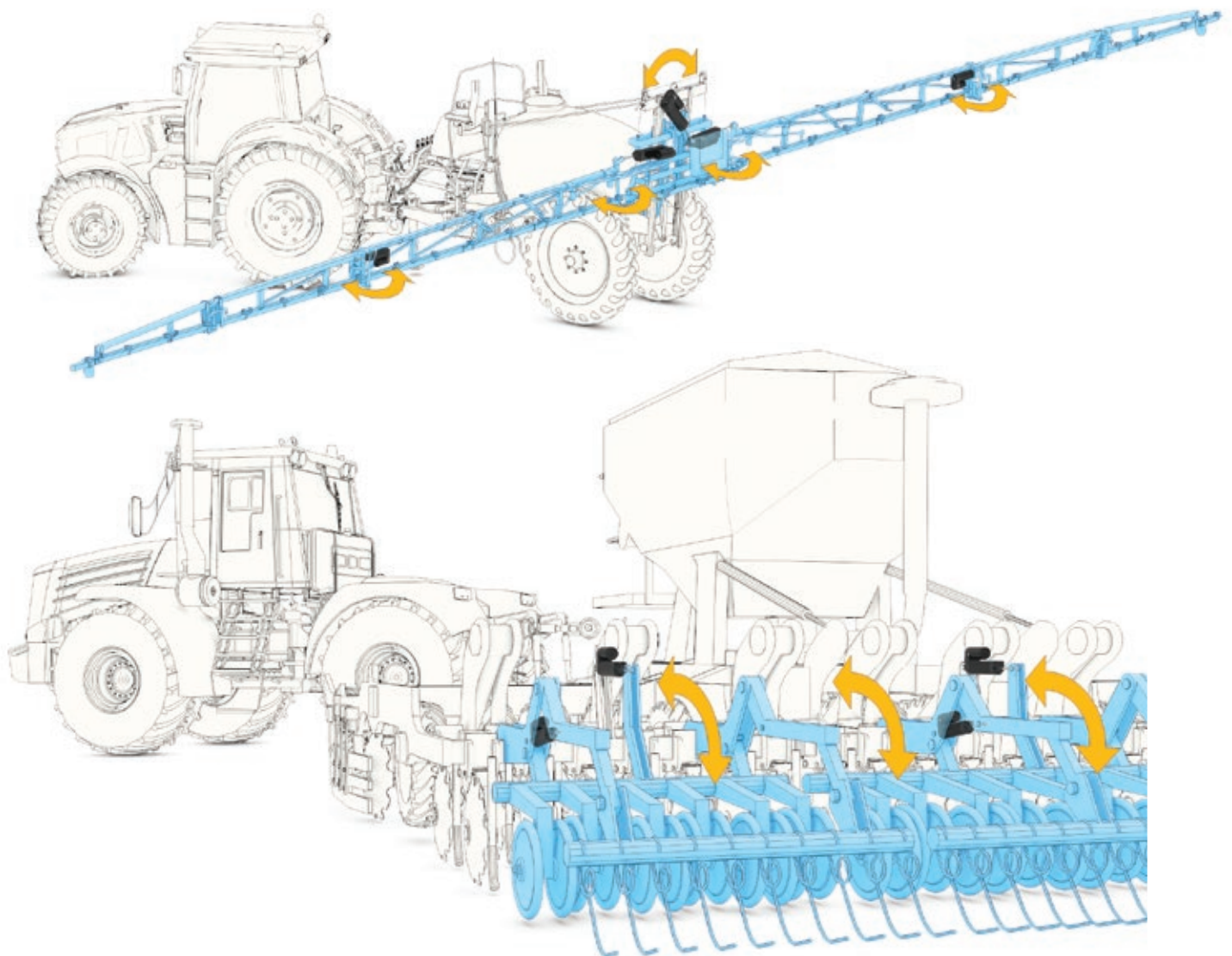

Ideal for Demanding Outdoor Applications

Where the often harsh outdoor environment creates conditions that can be fatal for most actuators, the H-Track thrives. A snow plow battling icy roads and striking a stationary, concrete object is an example that would quickly destroy most linear actuators. The H-Track's unique valve and reservoir design gives it the ability to cushion these blows and continue operating without issue. The optional ability to operate in temperatures as

low as -40°F (-40°C) makes it a perfect fit for even the coldest climates. Mower deck lifts are typically where electric actuators shine, but with increasing deck sizes and ground speeds, the limits of these traditional actuators are being exceeded. With its reliable, load-holding capabilities, enhanced durability for higher transport speeds, and the ability to withstand high-pressure washdowns, the H-Track is a perfect choice for the next generation of larger, faster mowers.

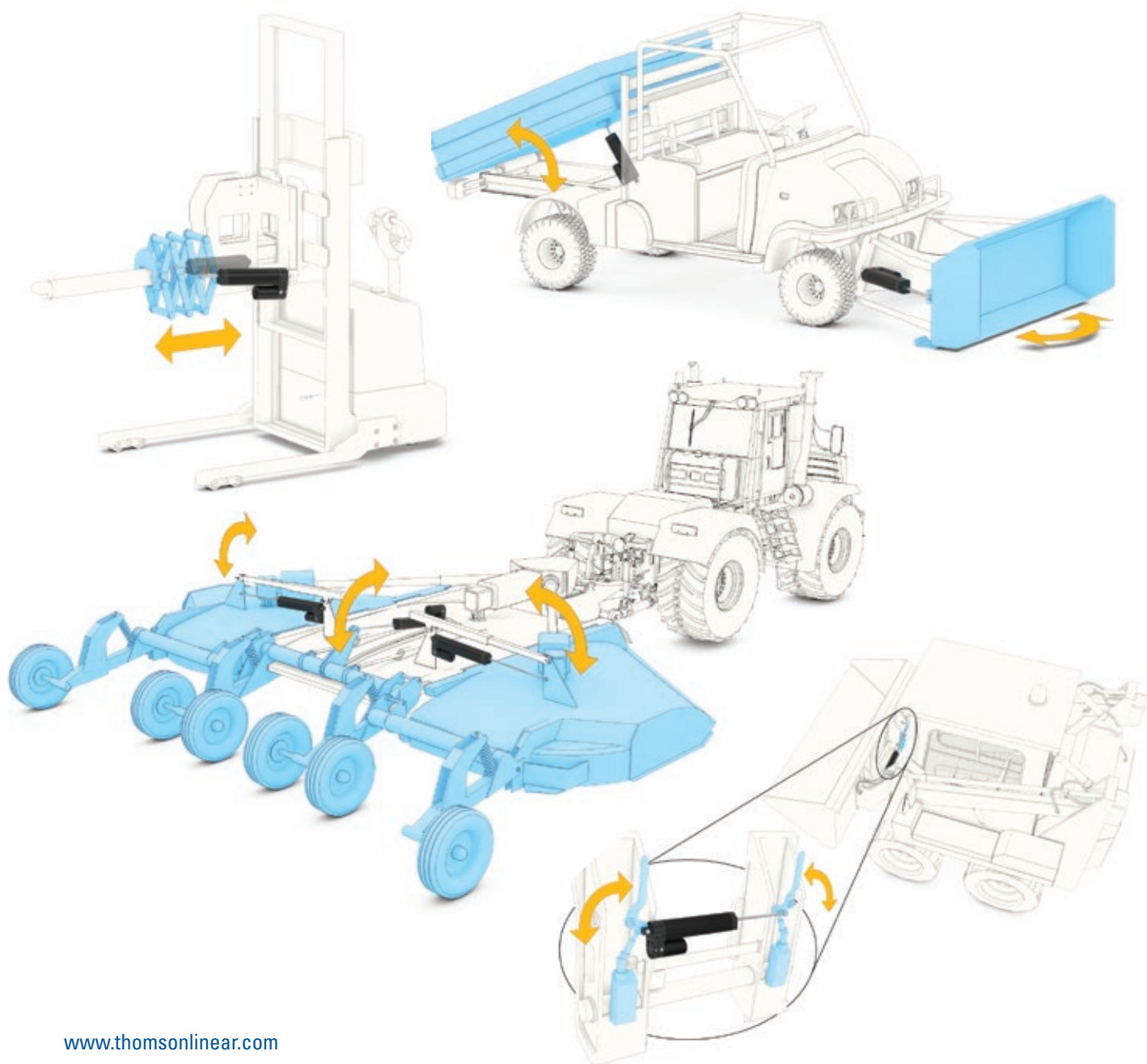



Marine-Grade Option Allows for Fully Submerged Operation

H-Track's marine-grade option earns it IP68 classification, meaning it can operate under water. Not only is this vital in marine applications, but it also eases design of any type of equipment that may be at risk of being submerged or flooded.

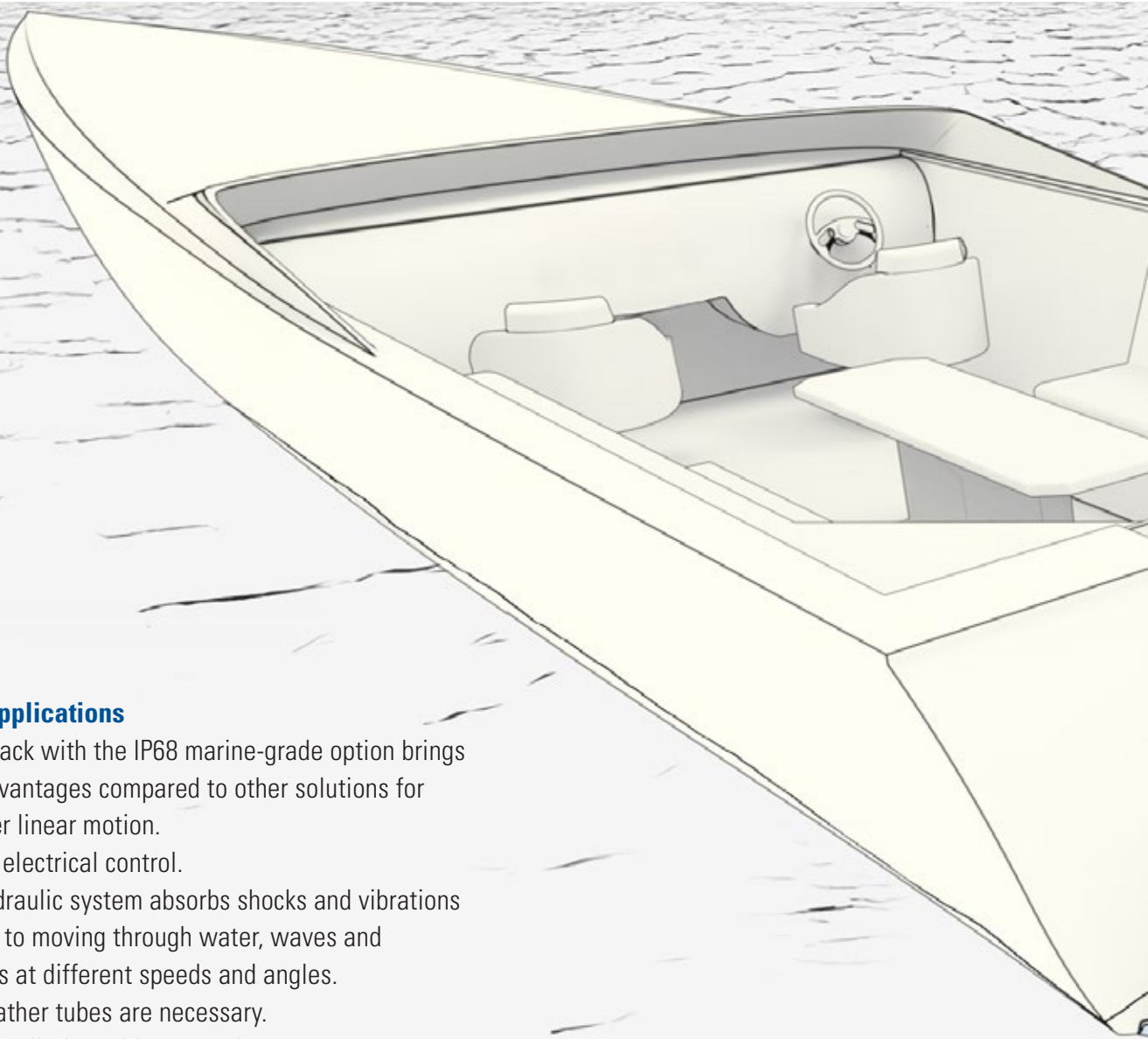

Marine Applications

Using H-Track with the IP68 marine-grade option brings several advantages compared to other solutions for underwater linear motion.

- Simple electrical control.
- The hydraulic system absorbs shocks and vibrations related to moving through water, waves and currents at different speeds and angles.
- No breather tubes are necessary.
- Easy installation with zero maintenance.

Other Underwater Applications

H-Track is the answer to many linear motion applications that need to be able to operate underwater occasionally or permanently - a need that few to none of today's standard solutions can fulfill.

- Equipment in cellars, wells or water tanks.
- Water treatment plants.
- Irrigation control applications.
- Small-scale hydro-power plants.
- Process machinery to control flow or hatches.
- Sewage and draining applications.
- Boat trailers and other waterfront vehicles.
- Loading docks that are susceptible to flooding.

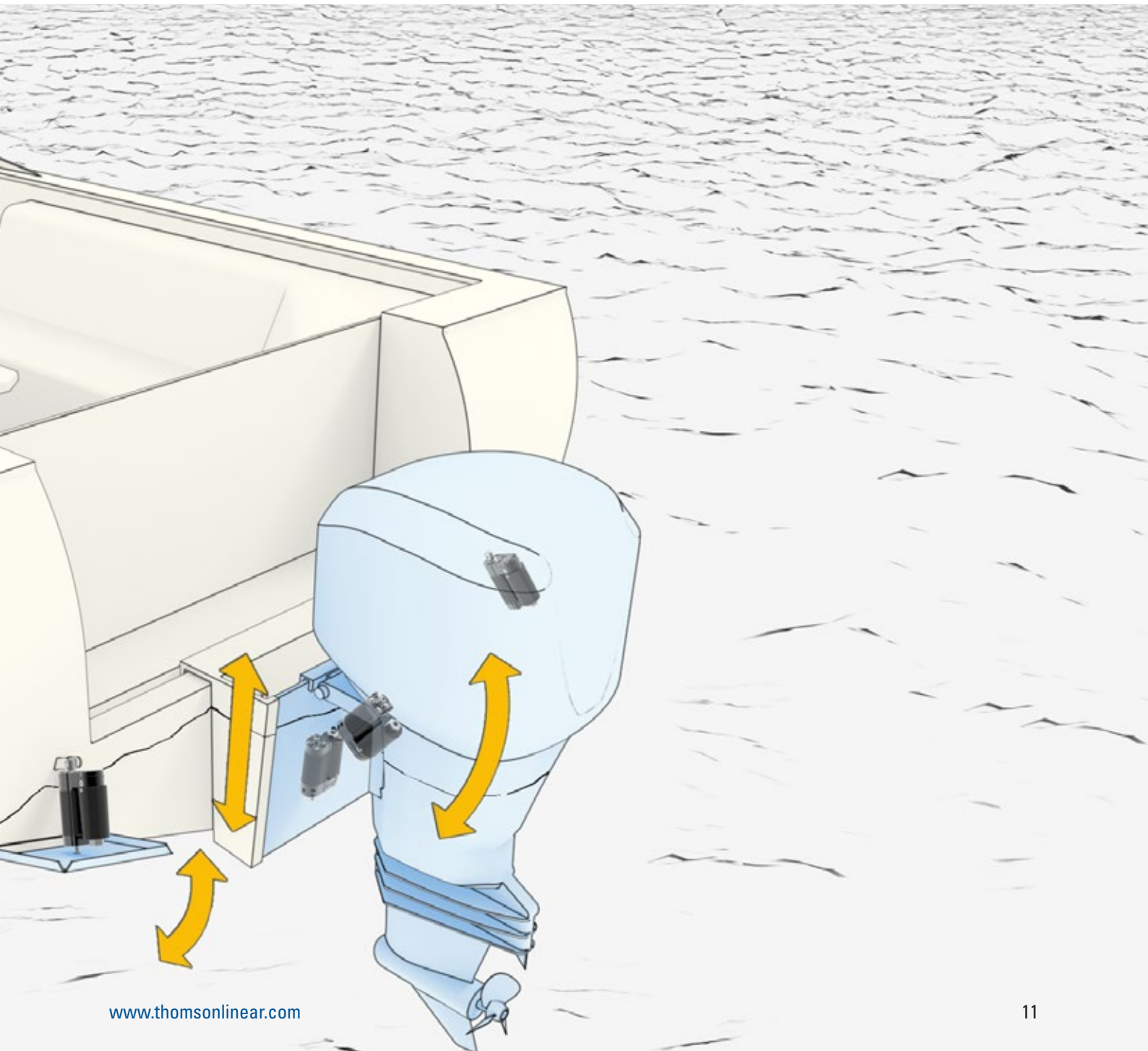



Technical Features



H-Track Electro-Hydraulic Linear Actuator

- Combines the best from the hydraulic and electric worlds.
- High power density.
- Very compact and short pin-to-pin versus stroke length relationship.
- Solid piston rod allows for increased resistance to buckling.
- Immune to vibrational drifting and hydraulically self locks.
- High shock load and vibration resistance.
- Fluid reservoir is vented and isolated from the atmosphere with a flexible lid, allowing actuator and pump operation in any orientation without entraining or cavitation.
- Standard strokes up to 12 in (300 mm).
- Designed for harsh outdoor conditions.
- IP68 marine-grade option for both static and dynamic operation.
- Reliable and maintenance free.

General Specifications

Cylinder type	hydraulic
Pump type	internal electric gear pump
Manual override	yes
Anti-rotation	no
Motor protection	built-in auto reset thermal switch
Static load holding brake	no (self-locking)
Pressure relief valve	yes (for both directions)
Electrical connections	
Motor size 1	flying leads + Packard 56 male connector
Motor size 2	flying leads + ring terminals
Motor size 3	flying leads + sealed IP67 rated Metri-pack 280 male connector
Compliance	CE, RoHs, REACH, Prop65

Optional Features

Mechanical options	IP68 marine-grade option
	Alternative front adapter ends
	Alternative rear adapter orientation

Technical Specifications

Mechanical Specifications		
Max. static compression load (Fx)	[lbf (N)]	5000 (22241)
Max. dynamic load (Fx)	[lbf (N)]	see page 18
Speed retract @ no load/max. load	[in/s (mm/s)]	see page 18
Speed extend @ no load/max. load	[in/s (mm/s)]	see page 18
Min. ordering stroke (S) length	[in]	2
Max. ordering stroke (S) length	[in]	12
Ordering stroke length increments	[in]	2
Operating temperature limits ⁽¹⁾⁽²⁾	[F (°C)]	-20 – 150 (-26 – 65)
Full load duty cycle @ 25 °C (77 °F)	[%]	25
End play, maximum	[in (mm)]	0.015 (0.4)
Restraining torque	[lb-in (Nm)]	0.89 (0.1)
Standard protection class - static		IP67/IP69K
Standard protection class - dynamic		IP65
Optional marine grade protection class - static and dynamic ⁽³⁾		IP68
Salt spray resistance ⁽⁴⁾	[h]	2000
Weight	[lb (kg)]	see page 15

1) Other limits possible, contact Thomson customer support for information.

2) H-Track can withstand air temperatures below the freezing point but must be protected from freezing while submerged in water.

3) Tested for 650 hours of submerged operation up to a depth of 2 meters (79 in) at rated duty cycle.

4) Tested per ASTM B117 (salt fog exposure for a duration of 2000 hours).

Electrical Specifications		
Available input voltages	[Vdc]	12, 24
Input voltage tolerance	[Vdc]	9 – 16 18 – 32
Current draw min/max	[A]	see page 18
Motor leads cross section	[AWG (mm ²)]	14 (2) 12 (3)
Motor ring terminals cross section	[AWG (mm ²)]	- 10
Motor lead length, standard	[in (mm)]	10 (254)

Electrical Connections

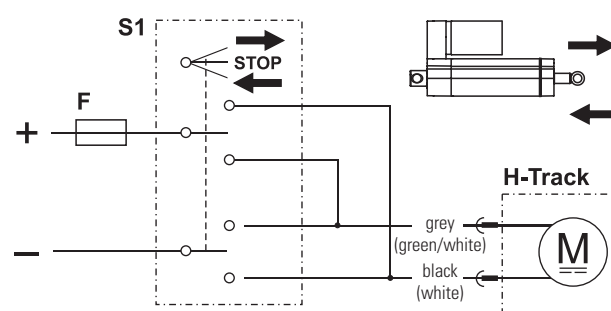

F Fuse

S1 Double pole double throw switch

To extend the actuator, apply +Vdc to black (white) and -Vdc to grey (green/white). To retract, apply -Vdc to black (white) and +Vdc to grey (green/white). Colors in between brackets are valid for motor size 2. Avoid running the actuator into the ends.



Dimensions

Dimensions	Projection
inch [mm]	

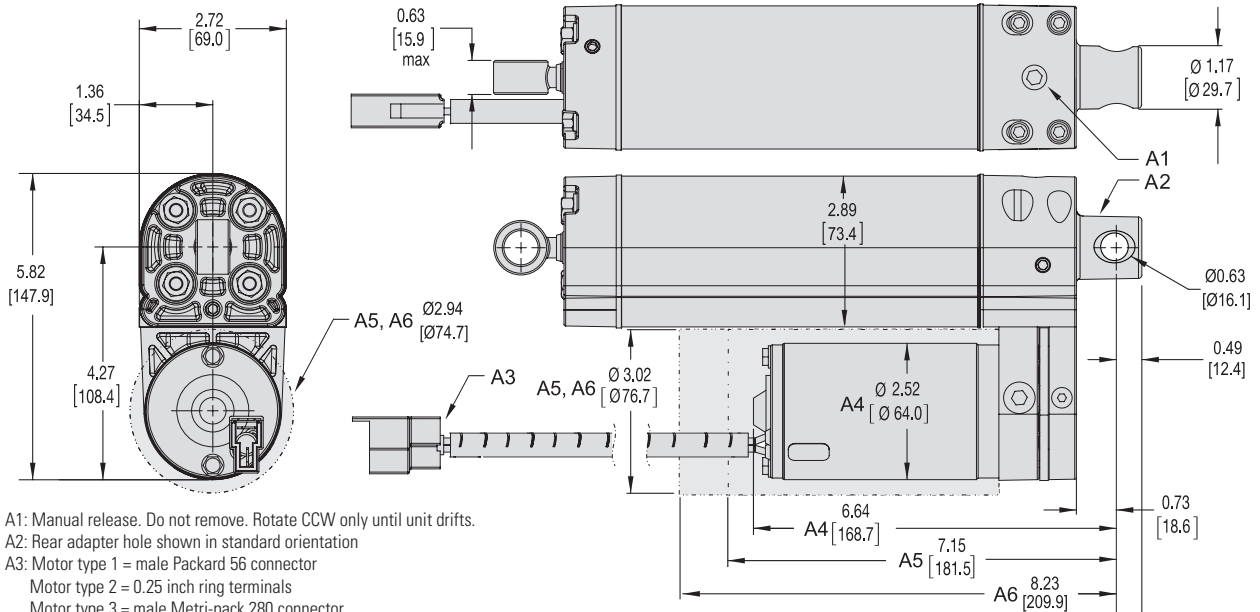

- A1: Manual release. Do not remove. Rotate CCW only until unit drifts.
- A2: Rear adapter hole shown in standard orientation
- A3: Motor type 1 = male Packard 56 connector
Motor type 2 = 0.25 inch ring terminals
Motor type 3 = male Metri-pack 280 connector
- A4: Motor type 1
- A5: Motor type 2
- A6: Motor type 3

Type A front adapter

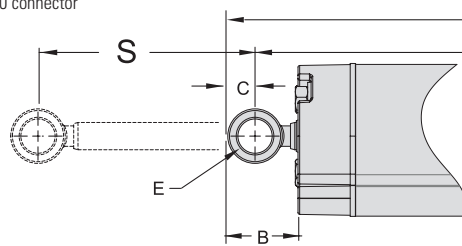

Type B front adapters

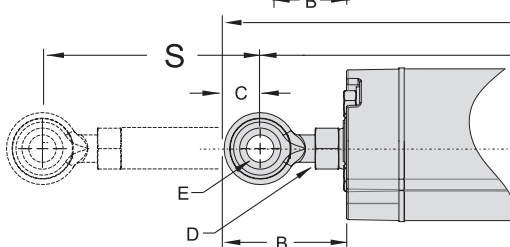

Type D front adapters

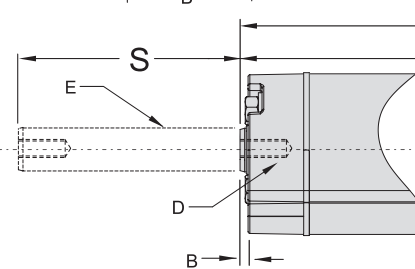

Type E front and rear adapter

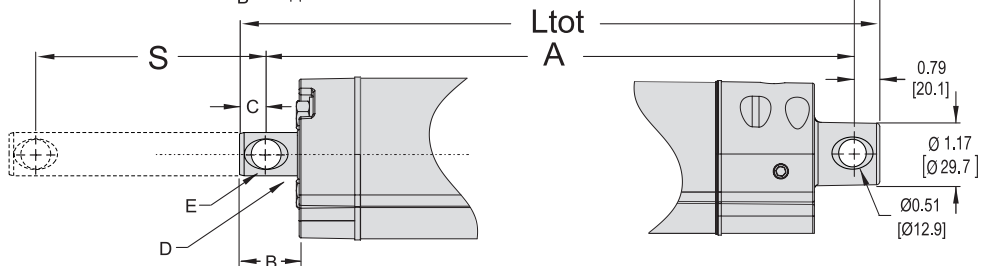

Dimensions

Dimensions [in (mm)]				
Front Adapter	Type A	Type B	Type D	Type E
Standard Ordering Strokes (S) [in]	2, 4, 6, 8, 10, 12			
Total Length (Ltot)	$L_{tot} = A + C + 0.49$ (12.4)	$L_{tot} = A + C + 0.49$ (12.4)	$L_{tot} = A + 0.49$ (12.4)	$L_{tot} = A + 0.46$ (11.7)
Retracted Length (A) Bore Size H2 Bore Size H3	A = S + 4.8 (121.9) A = S + 4.8 (121.9)	A = S + 5.4 (137.2) A = S + 5.7 (144.8)	A = S + 4.2 (106.7) A = S + 4.2 (106.7)	- A = S + 4.7 (119.4)
Dimension B Bore Size H2 Bore Size H3	1.31 (33.3) 1.31 (33.3)	1.66 (42.2) 1.89 (48.0)	0.14 (3.6) 0.14 (3.6)	- 1.03 (26.2)
Dimension C Bore Size H2 Bore Size H3	0.52 (13.2) 0.52 (13.2)	0.56 (14.2) 0.66 (16.8)	- -	- 0.46 (11.7)
Dimension D Bore Size H2 Bore Size H3	- -	7/16-20 THREADS 1/2-20 THREADS	7/16-20 THREADS 1/2-20 THREADS	- Ø 0.75 (19.0)
Dimension E Bore Size H2 Bore Size H3	Ø 0.631 (16.0) Ø 0.631 (16.0)	Ø 0.44 (11.2) THRU Ø 0.50 (11.2) THRU	Ø 0.625 (15.9) Ø 0.750 (19.0)	- Ø 0.51 (13.0)

Weight

Actuator Weight [lb (kg)]						
Actuator Type	Ordering Stroke (S) [in]					
	2	4	6	8	10	12
H2x-xx-1	6.9 (3.1)	7.8 (3.5)	8.7 (3.9)	9.6 (4.4)	10.5 (4.8)	11.4 (5.2)
H3x-xx-1	7.1 (3.2)	8.2 (3.7)	9.3 (4.2)	10.4 (4.7)	11.5 (5.2)	12.6 (5.7)
H2x-xx-2	8.5 (3.9)	9.4 (4.3)	10.3 (4.7)	11.2 (5.1)	12.1 (5.5)	13.0 (5.9)
H3x-xx-2	8.7 (3.9)	9.8 (4.4)	10.9 (4.9)	12.0 (5.4)	13.1 (5.9)	14.2 (6.4)
H2x-xx-3	9.3 (4.2)	10.2 (4.6)	11.1 (5.0)	12.0 (5.4)	12.9 (5.8)	13.9 (6.3)
H3x-xx-3	9.5 (4.3)	10.6 (4.8)	11.7 (5.3)	12.8 (5.8)	13.9 (6.3)	15.0 (6.8)



Ordering Key

Ordering Key								
1	2	3	4	5	6	7	8	9
H2	C-	12-	1	A2	2	-A	06	
<p>1. Bore size ⁽¹⁾ H2 = 1.375 in H3 = 1.500 in</p> <p>2. Load configuration ⁽¹⁾ N- = the piston rod is not influenced by external loading, with no external force driving it in or out of the actuator C- = external loading exerts a continuous force, driving the piston rod into the actuator H- = external loading exerts a continuous force, drawing the piston rod out of the actuator</p> <p>3. Input voltage ⁽¹⁾ 12- = 12 Vdc 24- = 24 Vdc</p> <p>4. Motor size and protection class ⁽¹⁾ 1 = 2.5 inch diameter, standard IP67/IP69K 2 = 3.0 inch diameter, standard IP67/IP69K 3 = 3.0 inch diameter, marine grade IP68 option ⁽²⁾</p> <p>5. Pump size ⁽¹⁾ B0 = 0.012 in³/rev B2 = 0.025 in³/rev B4 = 0.040 in³/rev</p>				<p>6. Piston diameter 2 = 0.625 in (always with bore size H2) 3 = 0.750 in (always with bore size H3)</p> <p>7. Adapter type -A = Standard -B = Spherical -D = Female Thread -E = Cross hole ⁽³⁾</p> <p>8. Stroke length ⁽³⁾ 02 = 2 in (50 mm) 04 = 4 in (100 mm) 06 = 6 in (150 mm) 08 = 8 in (200 mm) 10 = 10 in (254 mm) 12 = 12 in (300 mm)</p> <p>9. Rear adapter orientation blank = standard R90 = 90° position</p> <p>(1) See page 23 for sizing and selection guidelines (2) Motor option 3 not available for 24 Vdc (3) Cross hole not available with bore size H2 or motor type 2 (4) Other stroke lengths available upon request. Please contact customer support.</p>				



Performance Matrix

There are three main types of load configurations (N,C and H), which will determine the performance of the H-Track and how to interpret the below table. See the next page for information on the configurations and their effects.

Performance Matrix ⁽¹⁾										
Model	Max. Dynamic Load [lbf (N)]		Extend Speed [in/s (mm/s)]		Retract Speed [in/s (mm/s)]		Current Draw [A] ⁽²⁾			
	Extending	Retracting	@ No. Load	@ Max. Load	@ No. Load	@ Max. Load	12 Vdc Input Voltage		24 Vdc Input Voltage	
							Max.	Min.	Max.	Min.
Motor Type 1 (standard 2.5 inch diameter motor)										
H2x-xx-1B42	950 (4226)	750 (3336)	1.90 (48.3)	0.53 (13.5)	2.29 (58.2)	0.64 (16.3)	42	8	22	5
H3x-xx-1B43	1100 (4893)	825 (3670)	1.60 (40.6)	0.47 (11.9)	2.00 (50.8)	0.59 (15.0)	42	8	22	5
H2x-xx-1B22	1400 (6228)	1100 (4893)	1.20 (30.5)	0.34 (8.6)	1.45 (36.8)	0.41 (10.4)	42	8	22	5
H3x-xx-1B23	1750 (7784)	1300 (5783)	1.00 (25.4)	0.29 (7.4)	1.25 (31.8)	0.36 (9.1)	42	8	22	5
H2x-xx-1B02	2400 (10676)	1750 (7784)	0.50 (12.7)	0.15 (3.8)	0.60 (15.2)	0.18 (4.6)	42	8	22	5
H3x-xx-1B03	3200 (14234)	2400 (10676)	0.45 (11.4)	0.13 (3.3)	0.56 (14.2)	0.16 (4.1)	42	8	22	5
Motor Type 2 (standard 3 inch diameter motor)										
H2x-xx-2B42	1425 (6339)	1131 (5031)	1.90 (48.3)	0.53 (13.5)	2.29 (58.2)	0.64 (16.3)	80	14	43	10
H3x-xx-2B43	1650 (7340)	1238 (7340)	1.60 (40.6)	0.47 (11.9)	2.00 (50.8)	0.59 (15.0)	80	14	43	10
H2x-xx-2B22	2100 (9341)	1666 (7411)	1.20 (30.5)	0.34 (8.6)	1.45 (36.8)	0.41 (10.4)	80	14	43	10
H3x-xx-2B23	2625 (11677)	1969 (8759)	1.00 (25.4)	0.29 (7.4)	1.25 (31.8)	0.36 (9.1)	80	14	43	10
H2x-xx-2B02	3750 (16681)	2975 (13233)	0.50 (12.7)	0.15 (3.8)	0.60 (15.2)	0.18 (4.6)	80	14	43	10
H3x-xx-2B03	4800 (21351)	3600 (16014)	0.45 (11.4)	0.13 (3.3)	0.56 (14.2)	0.16 (4.1)	80	14	43	10
Motor Type 3 (marine grade motor)										
H2x-12-3B42	730 (3247)	625 (2780)	1.25 (31.8)	0.35 (8.9)	1.51 (38.4)	0.42 (10.7)	30	4	-	-
H3x-12-3B43	850 (3781)	684 (3043)	1.05 (26.7)	0.31 (7.9)	1.32 (33.5)	0.39 (9.9)	30	4	-	-
H2x-12-3B22	1079 (4780)	920 (4092)	0.90 (22.9)	0.26 (6.6)	1.09 (27.7)	0.31 (7.9)	30	4	-	-
H3x-12-3B23	1350 (6005)	1088 (4840)	0.75 (19.0)	0.22 (5.6)	0.94 (23.9)	0.27 (6.9)	30	4	-	-
H2x-12-3B02	1850 (8229)	1450 (6450)	0.65 (16.5)	0.31 (7.9)	0.81 (20.6)	0.38 (9.7)	30	4	-	-
H3x-12-3B03	2250 (10008)	1675 (7451)	0.55 (14.0)	0.26 (6.6)	0.71 (18.0)	0.34 (8.6)	30	4	-	-

1) The table above is valid for the temperature span of 40 – 120°F (4 – 50°C). H-Track can operate in the larger range of -20 – 150°F (-26 – 65°C), but at temperatures below 40°F (4°C), force and current begin to increase, while speed decreases. At temperatures above 120°F (50°C), speed will decrease slightly. The exact amount of performance change is difficult to calculate. Also, when it comes to the lower temperature span, the performance will move towards what is stated above as the temperature rises in the actuator due to the heat generated by its work. Please consult Thomson customer service for more information.

2) The current draw is not linear to the load but depends on and varies with the load configuration, direction of travel, ambient temperature, internal actuator temperature, and can not be easily determined for a specific situation. The above given max. and min. current draw is the highest respectively the lowest current draw you can expect during operation, and is what the power supply must be dimensioned for. Please consult Thomson customer service for more information.

Load Configuration

Configuration N

The piston rod is not influenced by external loading, with no external force driving it in or out of the actuator. Current draws are at maximum extending or retracting when the resistive load is at the maximum stated value.

Configuration C

External loading exerts a continuous force, driving the piston rod into the actuator. Current draws are at maximum while extending when opposing load is at maximum stated value. The current draw is between maximum and minimum while retracting the load. The current draw can be near the stated maximum value when retracting with no load.

Configuration H

External loading exerts a continuous force, drawing the piston rod out of the actuator. Current draws are at maximum while retracting when the opposing load is at maximum stated value. Current draw is between maximum and minimum while extending a helping-load. Current draw can be near the stated maximum value when extending with no load.

Caution: proper selection of Load Configuration is critical. Improper selection can result in unexpected performance.

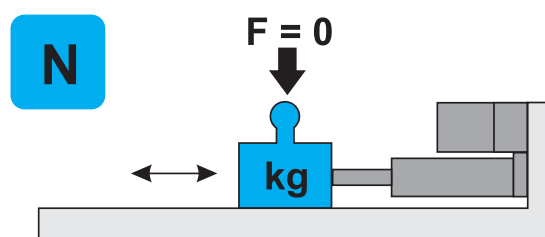

Configuration N: gravity does not affect the load in any direction.

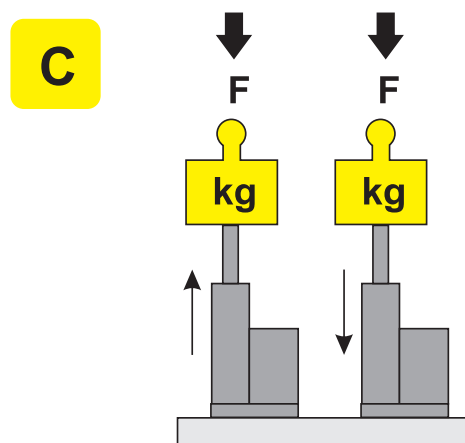

Configuration C: load is always acting to drive the piston rod into the actuator.

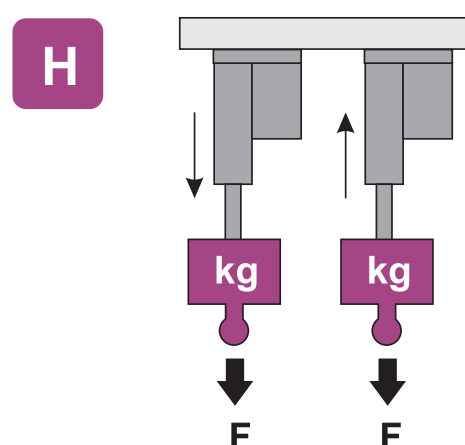

Configuration H: load is always acting to draw the piston rod out of the actuator



Bore Size

The maximum load in each direction and the required stroke length determine the minimum bore size needed for the actuator, which in turn, governs the piston diameter of the actuator.

Stroke vs. Load and Bore Size

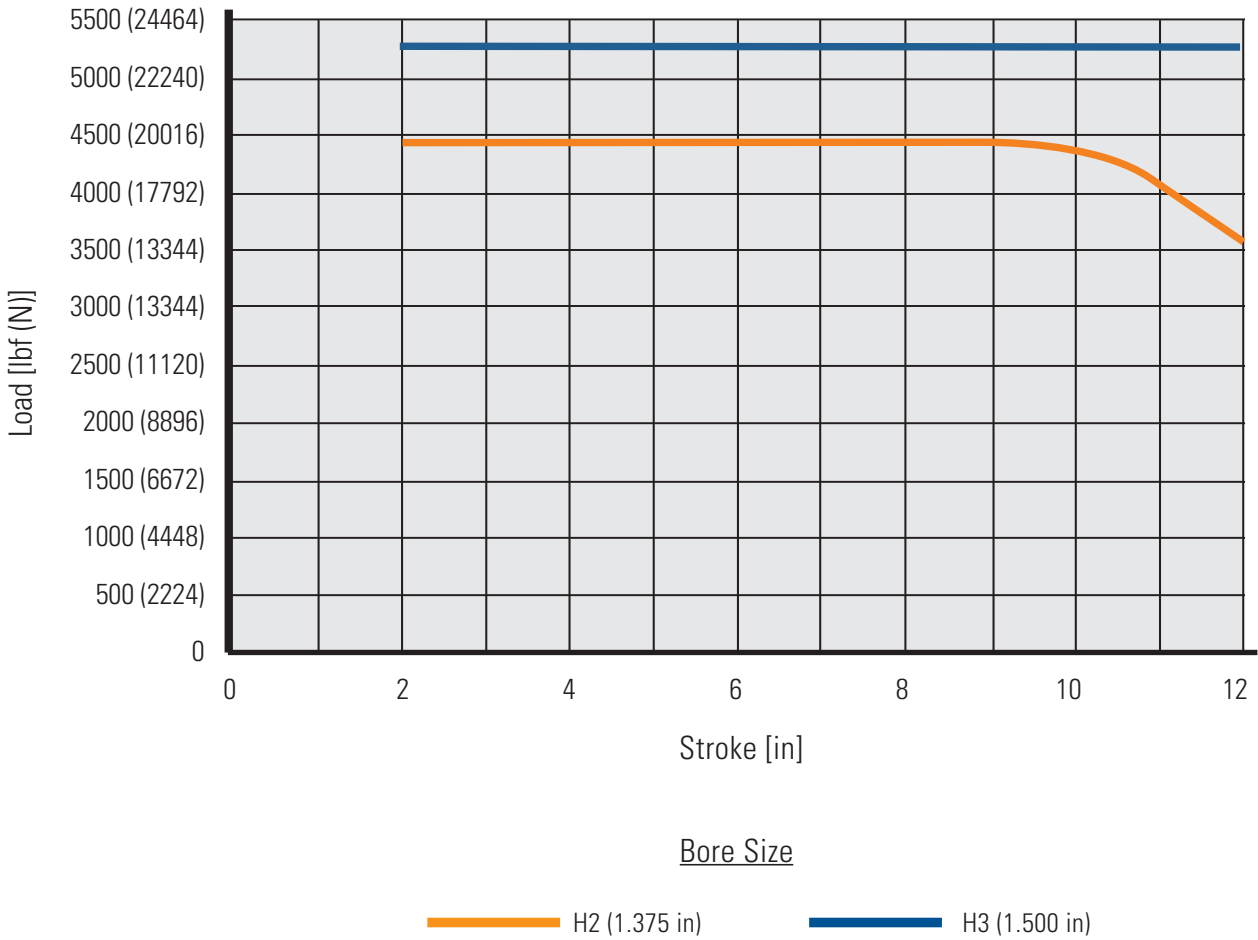

Motor and Pump Performance

Motor Type 1 - Load vs. Speed @ Extension / Retraction

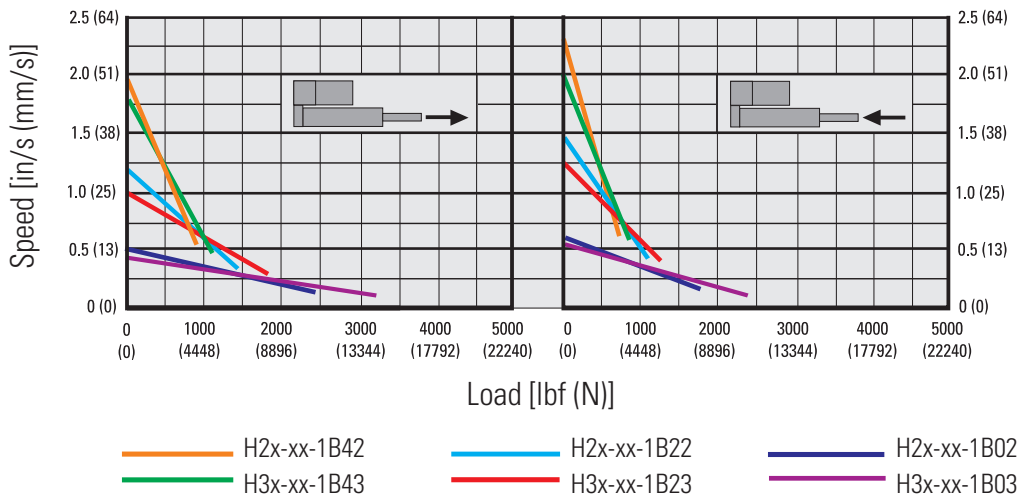

Motor Type 2 - Load vs. Speed @ Extension / Retraction

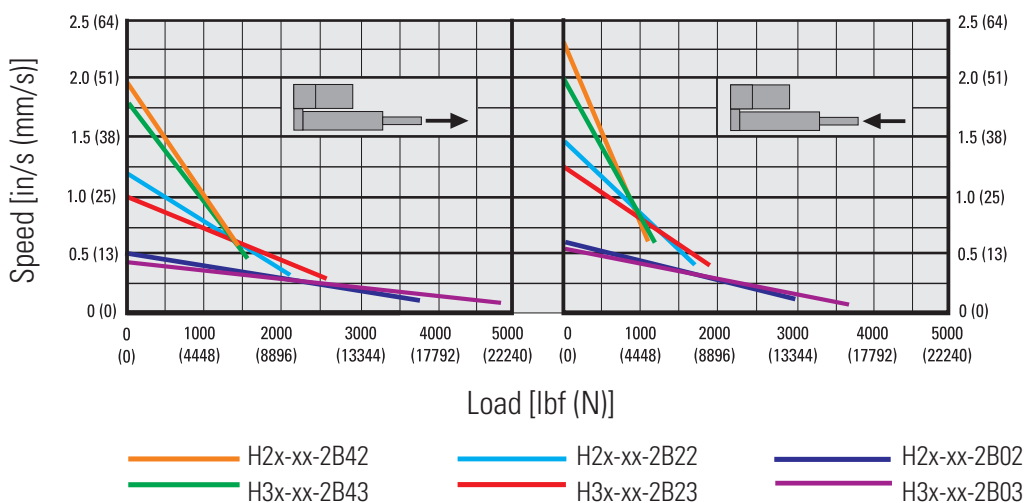

Motor Type 3 - Load vs. Speed @ Extension / Retraction

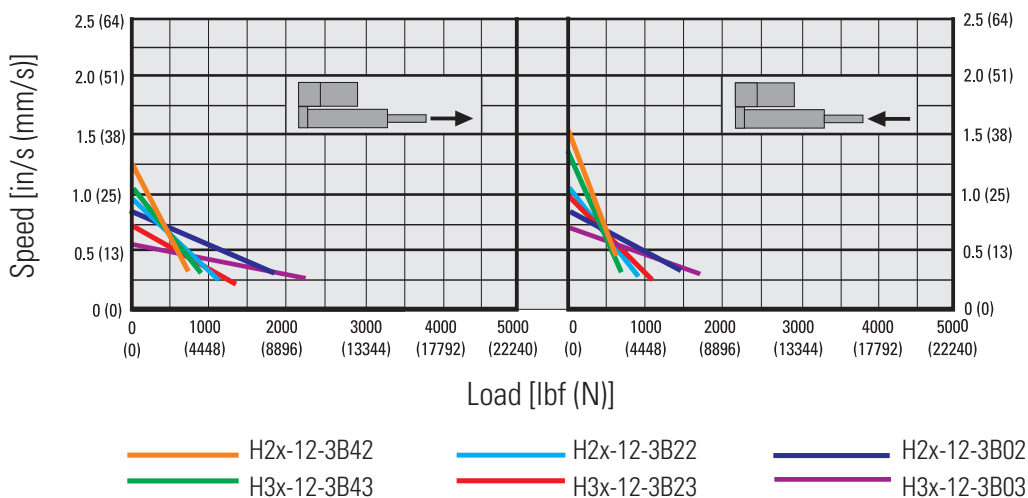



Sizing and Selection

In order to choose the optimal H-Track actuator for your application, please follow the sizing and selection process as described below. Do not hesitate to contact Thomson customer support if you need assistance.

Step 1. Collect the Necessary Application Data

In the following example, the application requirements are:

Stroke:	12 in
Max. load @ extension:	3750 lbf
Max. load @ retraction:	2000 lbf
Min. speed @ extension:	0.10 in/sec
Min. speed @ retraction:	0.25 in/sec
Input voltage:	24 Vdc
Protection class:	IP67
Type of load:	the load is pushed and pulled horizontally

Step 2. Bore and Piston Sizing

Determine the bore size (which also gives you the piston diameter) for your load and stroke. Also see page 20.

Example: As the application requires a 12-in stroke, that can handle 3750 lbf at extension (red dot) and 2000 lbf at retraction (yellow dot), then the Stroke vs. Load and Bore Size diagram below shows, that only the blue curve is above both points. Therefore, bore size H3 is the only possible choice in this case (which also means the piston diameter will be 0.750 in).

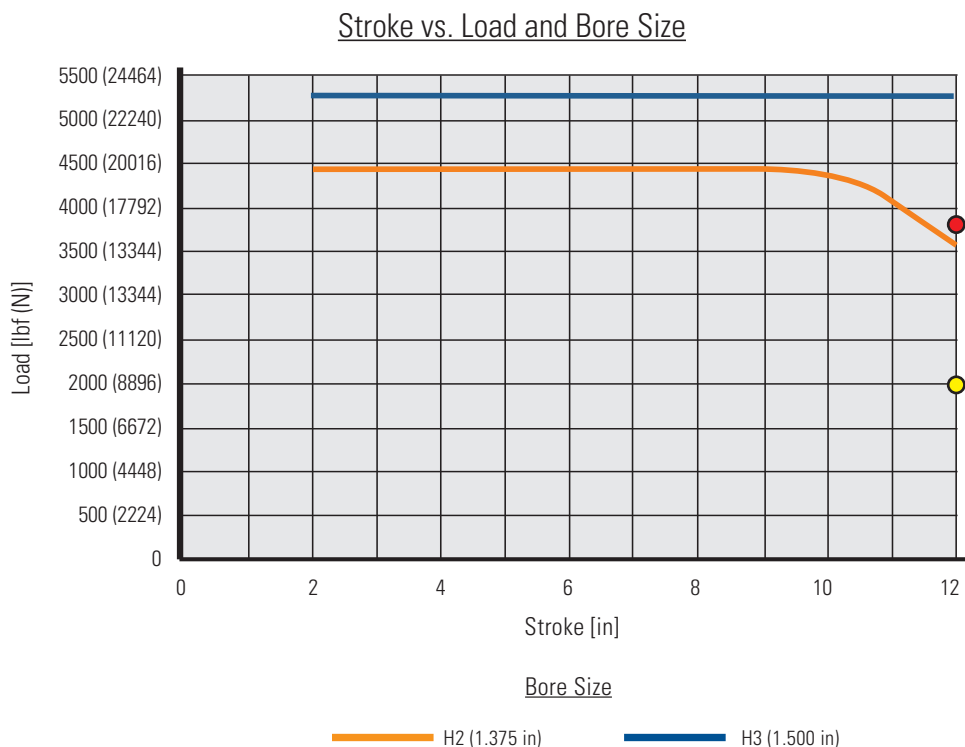

Sizing and Selection

Step 3. Sizing of Motor and Pump

Determine the size of the motor and pump for your application using the performance diagrams on page 21.

Example: The combined IP67 and 24 Vdc input voltage requirements directly rules out motors of type 3 since they are available for 12 Vdc only. Next, looking at the diagrams for motor types 1 and 2 shows that only the type 2 diagrams have motors capable of handling the required 3750 lbf extension load. Placing the maximum extension (red arrow) and retraction loads (yellow arrow), plus the desired extension (green arrow) and retraction (blue arrow) speeds in the type 2 diagram show that there are two motor sizes capable of handling both the loads and speeds (H2x-xx-2B02 and H3x-xx-2B03). However, the only possible choice is H3x-xx-3B02 since it has the required H3 bore size. Hence the ordering code at this stage reads H3x-24-3B02-x-12x.

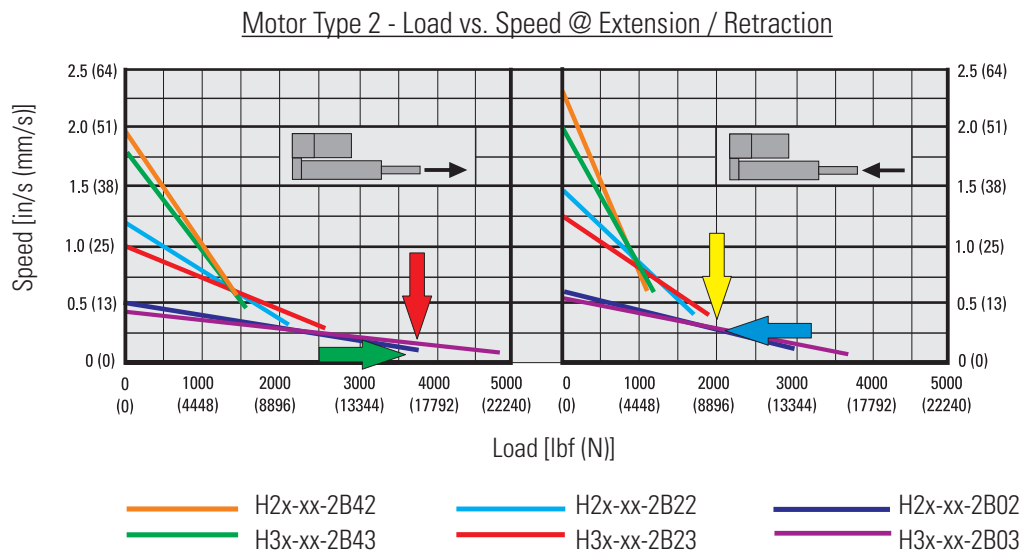

Step 4. Current Draw

The Performance Matrix on page 18 shows that model H3x-24-2B03 will draw up to 43 A and never less than 10 A (since it has 24 Vdc input voltage). The power supply will need to be dimensioned accordingly.

Step 5. Load Configuration

Choosing the correct load configuration for the actuator is critical for proper operation and will also determine the current consumption profile during operation. Also see page 19.

Example: Since the load is pushed and pulled horizontally, the corresponding load configuration is N, and current draws will therefore be at maximum at extension or retraction when the opposing load is at the maximum stated value. The ordering code at this stage now reads H3N-24-2B03-x-12x.

Step 6. Finishing the Ordering Code

In order to complete the ordering code, the type of piston rod front adapter and the rear adapter orientation need to be added to the code. Also see page 17.

Example: If we assume a standard front adapter and a 90° rear adapter orientation are required, the complete ordering code would be H3N-24-2B03-A-12R90.



Online Resources

Thomson offers a wide variety of online tools to help you in the sizing and selection process. An experienced team of engineers is also available to help size and select an H-Track model to best fit your application needs. To explore additional technical resources and options, contact customer support at www.thomsonlinear.com/cs.

H-Track on the Web

Get additional information and learn more about H-Track on this content-rich web page. www.thomsonlinear.com/h-track

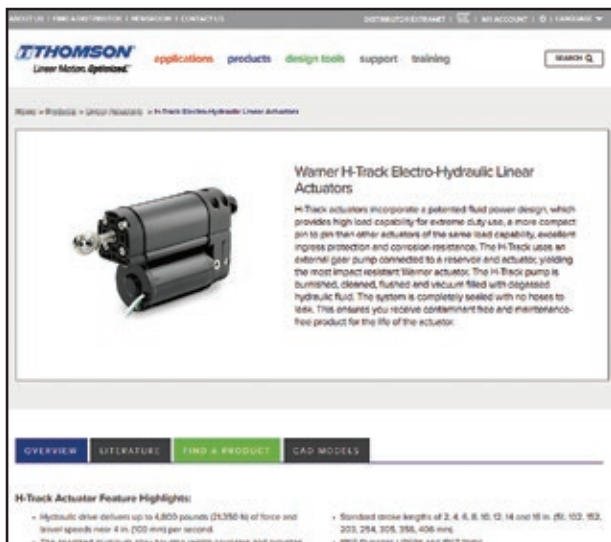

H-Track Overview Video

Learn about this electro-hydraulic actuator with this brief, informative video. www.thomsonlinear.com/H-Track-video



Interactive 3D CAD Models

Download free interactive 3D CAD models in the most common CAD formats. www.thomsonlinear.com/H-Track-cad

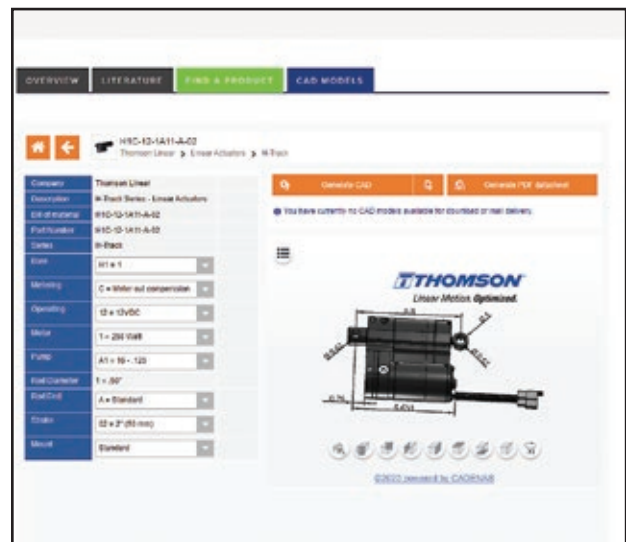

H-Track Marine-Grade Option Video

This video details the advantages of H-Track's IP68 marine-grade option. www.thomsonlinear.com/H-track-marine-video

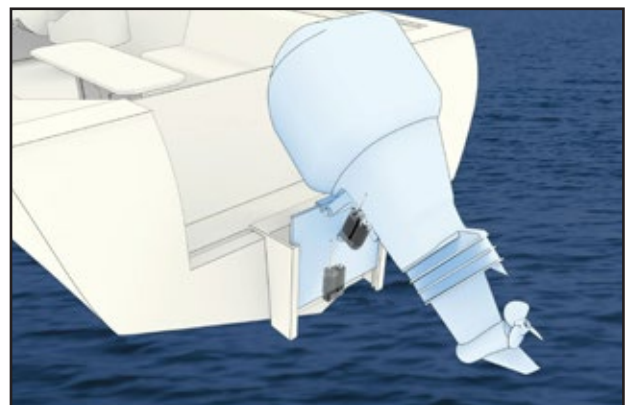

Frequently Asked Questions

What is the typical life of an actuator?

Life is a function of load and stroke length. Please contact customer support for more information.

What are the most common reasons for premature actuator failure?

Side load due to incorrect mounting, shock loading, exceeding the duty cycle and incorrect wiring are the most prominent causes of premature failure.

Is H-Track maintenance free?

Yes, it never requires lubrication, maintenance or adjustment for wear.

What are IP ratings?

Ingress Protection (IP) ratings are commonly referenced standards that classify electrical equipment using standard tests to determine resistance to ingress of solid objects (first digit) and liquids (second digit). See the IP Ratings table below.

Is H-Track suitable for tough environments such as washdown or extreme temperatures?

Yes. H-Track actuators are designed for washdown and have passed 2000 hours of salt spray tests. They can operate in temperatures ranging from -20 to +65°C (-20 to +150°F).

How is the duty cycle determined?

The duty cycle = on time / on time + off time. For example, if H-Track is powered for 15 seconds and then off for 45 seconds, the duty cycle for that minute would be 25%. All models are rated to 25% at full load, and an ambient temperature of 25°C (77°F). If load and/or ambient temperature are lower, then the duty cycle can exceed 25%. At higher temperatures, the duty cycle will be lower.

Can H-Track be side loaded?

No. A proper design of the application should eliminate any side loads.

IP Rating (EN60529)		
Code	First Digit Definition	Second Digit Definition
0	No protection.	No protection.
1	Protected against solid objects over 50 mm.	Protected against vertically falling drops of water.
2	Protected against solid objects over 12.5 mm.	Protected against vertically falling drops of water, if the case is disposed up to 15° from vertical.
3	Protected against solid objects over 2.5 mm.	Protected against vertically falling drops of water, if the case is disposed up to 60° from vertical.
4	Protected against solid objects over 1 mm.	Protected against splash water from any direction.
5	Limited protection against dust ingress (no harmful deposits).	Protected against low-pressure water jets from any direction. Limited ingress permitted.
6	Totally dust protected.	Protected against high-pressure water jets from any direction. Limited ingress permitted.
7	–	Protected against short periods of immersion in water.
8	–	Protected against long duration periods of immersion in water.
9K	–	Protected against close-range, high-pressure and high-temperature spray downs.



Frequently Asked Questions

Is it possible for a load to back-drive the piston rod?

H-Track is self locking up to at least the maximum static load. Higher static load may result in damage and back driving.

What is the difference between a tension and a compression load?

A tension load tries to stretch the actuator, while a compression load tries to compress it. With bi-directional loads, the end play of the actuator piston rod may need to be taken into consideration when using the actuator for positioning tasks.

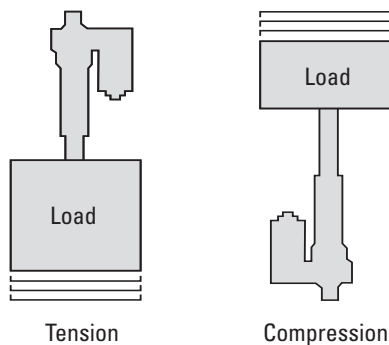

What is a helping load?

A helping load is a load that enhances acceleration in the direction the actuator is moving. This can be loads that are accelerated by gravity, spring force, etc. that assist the intended motion of the actuator.

What is a counteracting load?

A counteracting load is a load that resists acceleration in the direction the actuator is moving. This can be loads that are accelerated by gravity, spring force, etc. that oppose the intended motion of the actuator.

What is the range of input voltage an H-Track can operate with?

A 12 Vdc version will accept 9 – 16 Vdc and a 24 Vdc 18 – 32 Vdc. Outside of these limits, operation may be erratic and the actuator permanently damaged.

Is H-Track protected against overheating?

Yes, the motor incorporates a thermal switch in the windings to shut off the actuator motor in case of overheating or high overcurrent.

Can the speed of an H-Track be adjusted by changing the input voltage?

Yes, as long as the voltage is within the acceptable input voltage limits.

What is the inrush current?

The inrush current is a short current peak that appears at the start of an actuator as the motor tries to get the load moving. Typically, the inrush current will last between 75 – 150 milliseconds and can be up to three times higher than the current for the actuator and load. Batteries have no problem delivering the inrush current, but if using an AC power supply, it is important to size it to handle the inrush current.

What special mounting considerations does the H-Track require?

There is no restraining torque that needs to be considered as H-Track is internally restrained. However, the actuator must be mounted so that there are no side loads acting on the piston rod.

Frequently Asked Questions

What is the maximum travel speed?

The travel speed of an H-Track actuator is a linear function of the load. To determine the speed at a certain load and direction, consult the load vs. speed diagrams on page 21. If a higher linear travel speed is required, a simple mechanical linkage can be employed.

What is a meter-out circuit?

A meter-out circuit is a method used inside the H-Track actuator to control the hydraulic fluid flow to prevent the actuator from overrunning and help regulate the influence from helping loads. While this is a very useful technology, it makes the current draw in relation to the speed of an H-Track hard to predict. In most cases, only the maximum and minimum current draw are meaningful.

Contact us or any of our 2000+ global distribution partners by scanning the code below
or visiting www.thomsonlinear.com/contact



RegalRexnord™

www.regalrexnord.com

www.thomsonlinear.com

H-Track_BRUK-0035-06 | 20260218KB | MCB-12401-TL-EN-A4 02/26
Specifications are subject to change without notice. It is the responsibility of the product user to determine the suitability of this product for a specific application. All trademarks property of their respective owners. ©2026 Thomson Industries, Inc. | 2400 Curtiss Street, Downers Grove, IL 60515 USA

THOMSON®